

LINDEN TABLE LAMP - NARROW

DUNN

DESCRIPTION

A contemporary table lamp with a linen shade and body, hardwood base, and brass details. The structural shape is derived from classic mid-century modern form language. Linen fabric gives a lustrous, glowing quality.

DETAILS

Lead Time | 8-10 Weeks

Materials | Linen, brass, steel, hardwood

Weight | 4.5 lbs

Dimensions | 25" Height x 16" Diameter

Lamping | 120V/60Hz, E26 socket, 60W max

Made In | USA



FRONT VIEW

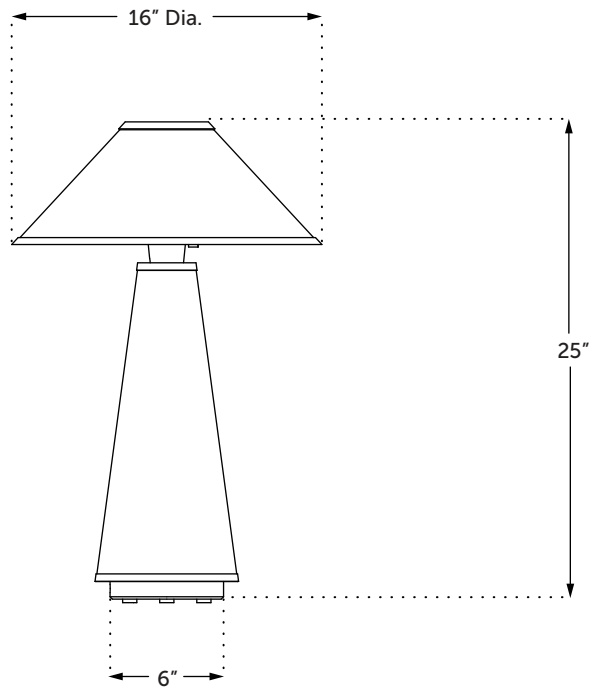

FINISH OPTIONS

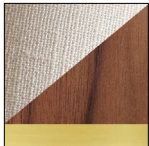

LND-TL-16X25-CL-WB
Cream Linen Shade
and Lamp Body
Walnut Base
Brass Details



LND-TL-16X25-CH-MB
Charcoal Linen Shade
and Lamp Body
Maple Base
Brass Details

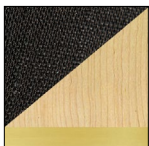

LND-TL-16X25-BL-MB
Black Linen Shade
and Lamp Body
Maple Base
Brass Details

BULBS

Sold separately. Please visit our website for details. Many styles of bulbs work with our fixtures. Refer to the lamping specifications to determine compatibility.

CUSTOMIZATION

Please contact us for customization options.

Finish samples sold online.

(401)-400-0206
info@studiodunn.com
www.studiodunn.com

Each piece is built to order.

310 Bourne Ave
Building #1
Rumford, RI 02916

Designed by Studio DUNN, 2021

For quotes & custom inquiries
please contact Studio DUNN:
info@studiodunn.com